

# RAYMOND® 120” ROLLER MILL

With a 130 years of experience, Raymond is a leader in the design and manufacture of industrial milling equipment and has set the standard in size reduction.

## ADVANTAGES

- Efficient control of product size with minimal power resulting in cost-effective production.
- Maximum flexibility and control over mill variables, delivering controlled product quality at minimum operating costs.

## For Greater Mill Capacity

The Raymond 120” Roller Mill System: Developed to address the growing demand for limestone sorbent and solid fuel alternatives to coal requiring greater capacity mills. Pendulum style roller mills have a proven performance record for sorbent preparation for PC’s and CFB’s as well as petroleum coke grinding.

### System Overview

The Raymond Roller Mill is an airswept vertical ring-roll mill with an integral classification system. A vertical shaft rotates a “spider” assembly of arms from which are suspended free-swinging journal assemblies with rolls attached. As the unit turns, centrifugal force drives the rolls against the inner surface of the vertical grinding ring. Plows, rotating with the assembly, lift feed material from the mill bottom and direct it between the rolls and the grinding ring where it is pulverized. Air enters from below the grinding ring and flows upward, carrying fines to the classifying section. The classifier sizes the pulverized materials and returns oversized particles to the grinding chamber for further processing.

The typical system is designed to dry, pulverize, classify and deliver a number of different types of materials. From a feed ranging in size from approximately 10-70mm (0.5-3.0 in.), the roller mill can produce particles ranging from coarse, granular to fine powders. The mill is most effective processing materials that are 5 or less on the Mohs scale of hardness.

The Raymond 120” Roller Mill continues the line with its increased capacity and new design features..

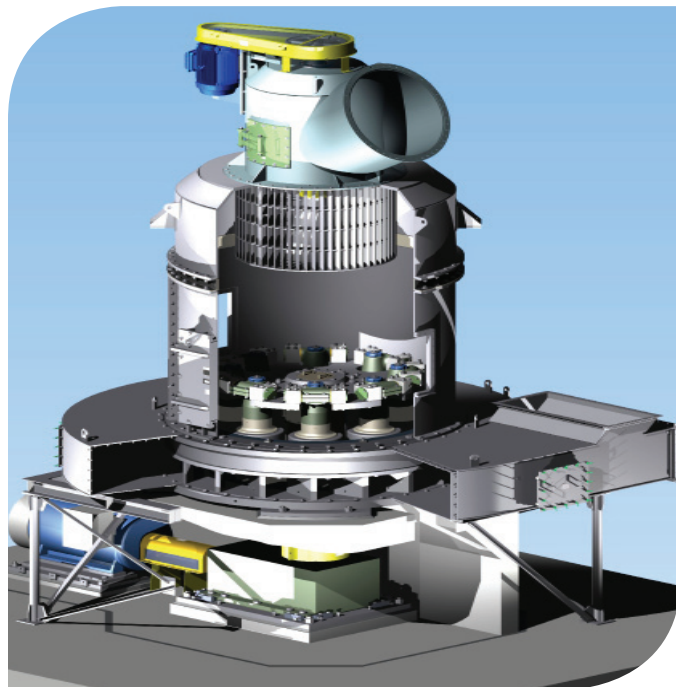

# RAYMOND® 120” ROLLER MILL

## Airflow and Power Requirements for Raymond Roller Mill

Mill Size		Nominal Airflow		Mill Power (Max)		Turbine Power	
in	mm	ft <sup>3</sup> /min	m <sup>3</sup> /hr	hp	kW	hp	kW
30	760	3,900	6,600	30	22	25	18
50	1270	10,000	16,900	100	75	30	22
54	1370	12,600	21,400	150	110	40	30
60	1520	15,600	26,500	200	160	50	45
66	1670	22,500	38,200	300	225	75	55
73	1850	31,000	52,600	600	500	100	75
87	2180	46,500	79,000	900	700	150	110
<b>120</b>	<b>3050</b>	<b>100,000</b>	<b>169,000</b>	<b>1,500</b>	<b>1,200</b>	<b>200</b>	<b>150</b>

## Construction Features

- Journal Assembly - utilizes fewer total components, improved seal design and anti-vibratory bearings.
- Trunnion Bearings Dual O-Ring - design features better sealing and reduced trunnion shaft wear.
- Vertical Shaft to Hub Connection - hybrid taper lock/keyless locking connection reduces disassembly difficulties associated with full taper-lock.
- Fabricated Plow Support - incorporates access opening for visual inspection of the vertical shaft's upper seals and bearings.
- Turbine Classifier Flange Bearing - allows for easier maintenance of bearings and seals.

